



**SCENARIOS OF ELECTRO-MOBILITY:  
CROSS-FERTILIZATION AND  
DISSEMINATION OF BEST PRACTICES  
AND RESEARCHES WITHIN EU POLICIES**

## **WEBINAR PROCEEDING**



*Co-financed by H2020  
Programme - GA 769944*



**CITTA' DI TORINO**



**POLITECNICO  
DI TORINO**

---

## Status of the Webinar Report:

February 2021

## Involved Project Partners:

CITY OF TORINO, POLITECNICO DI TORINO, INFINEON TECHNOLOGIES AUSTRIA, JAC ITALY DESIGN CENTER SRL, IDEAS & MOTION SRL, VEHICLE ELECTRONIC MANUFACTURING SOLUTIONS SRL, ANYSOLUTION SL, UNIVERSITY OF SURREY, CISC SEMICONDUCTOR GMBH, OSPEDALE SAN RAFFAELE SRL, CITY OF VENARIA REALE

## Authors/Edition Team:

Francesca BENA, Giuseppe ROCCASALVA, Pierrick LE GUILLOU, Maria LAPIETRA, Johan MASSONER, Dolores ORDÓÑEZ, Maurizio VERONESE, Diego CIPOLLINA, Mathias FEISBERGER, Aldo SORNIOTTI, Daniele BARANZINI, Xu Mei Hua, Markus PISTAUER, Marco ANNONI, Massimo VIOLANTE, Riccardo GROPPPO, Paolo GUGLIELMI, Federico BONI CASTAGNETTI, Dragan ŠIMIĆ, Ines MUNOZ, Angelos J. AMDITIS, Giuseppe ESTIVO.

## Organising Committee

The STEVE webinar **Organising Committee** consisted of the following partners:

- **City of Torino - Innovation, EU Funds Division**

Fabrizio Barbiero  
Francesca Bena  
Michele Fatibene  
Daniela Silvi

- **City of Torino - Mobility Division**

Roberto Bertasio  
Giuseppe Estivo

The STEVE webinar **Scientific Committee** consisted of the following partner

- **Polytechnic of Turin**

Giuseppe Roccasalva, research advisor, Ph.D. at Department of Architecture and Design (DAD)

© 2021 Urban Lab Torino

All rights reserved

First Edition: February 2021

ISBN 9788861730106



**POLITECNICO  
DI TORINO**



<b>EXECUTIVE SUMMARY</b> .....	<b>4</b>
<b>STEVE PROJECT</b> .....	<b>5</b>
<b>Fact Sheet</b> .....	<b>5</b>
<b>Introduction</b> .....	<b>6</b>
<b>OBJECTIVES OF THE STEVE WEBINAR</b> .....	<b>7</b>
<b>HIGHLIGHTS OF THE WEBINAR, SESSION PER SESSION</b> .....	<b>8</b>
<b>WELCOMING SPEECHES</b> .....	<b>8</b>
<b>WORKING SESSION I - STEVE PROJECT AND ITS MAIN RESULTS</b> .....	<b>10</b>
The STEVE project.....	10
SmartMobility in SmartDestinations: STEVE pilot in Mallorca.....	12
MaaS Mobility As A Service .....	14
STEVE pilot in Villach.....	16
City of Venaria perspectives to develop Maas system .....	17
<b>WORKING SESSION II - USERS CENTRIC E-DESIGN FOR INNOVATIVE TECHNOLOGIES AND SERVICES</b> .....	<b>20</b>
Users centric e-design for innovative technologies .....	20
Technical developments on energy-efficient torque-vectoring and speed profiling .....	22
Are we entering in E-GO AGE?.....	24
Users services scenarios.....	25
Telematics: enabler for vehicular MaaS.....	26
Communication & Gamification.....	27
Innovation in automotive devices for electro mobility.....	28
<b>WORKING SESSION III - POLICY RECOMMENDATION FOR ELECTRO MOBILITY</b> .....	<b>30</b>
INCIT-EV H2020 project.....	30
QUIET H2020 project .....	32
DOMUS H2020 project.....	34
ELVITEN H2020 project .....	36
INCIT-EV H2020 project.....	38
Local perspective on future mobility vision .....	40
<b>CONCLUDING REMARKS</b> .....	<b>42</b>
<b>Annex 1 - WEBINAR AGENDA</b> .....	<b>44</b>
<b>Annex 2 - SHORT PROFILES OF THE SPEAKERS AND SCIENTIFIC COMMITTEE</b> .....	<b>45</b>



## EXECUTIVE SUMMARY

This book of proceedings trace and comment the discussions of the webinar held in may 2020 and titled "Scenarios of Electromobility: cross fertilization and dissemination of best practices and researches within Eu Policies". The ultimate goal of the event and the book are to enhance the dissemination of EU STEVE project and boost the debate among different practitioners, public officials and stakeholders. The event was design by the organizing and scientific committee in order to depict, in a nutshell, innovative researches, technologies and political approaches to e-mobility by addressing the most recent eu-funded projects The aim of the webinar were threefold:

- the scientific/organizing committee managed to set up an interactive process which exploited the opportunity , and the constraint, of being virtually connected, and at the same time gave the possibility to display the main results of the EU project working on sustainable mobility. In this regard, the overall streaming of the webinar was recorded in order to be available also in an asynchronous modality. The webinar was also synthetically and critically summarised in this open digital document which has the possibility to be continuously improved and commented by the readers.
- the scientific/organizing committee has decided to select and invite representative persons from the main research experiments on electro mobility which were financed under the H2020 calls in order to have a cross contamination among the project's ongoing results. On this matter, projects Quiet and Domus have shown critical issues and opportunities on the field of user centric design of electric vehicles. Projects Steve and Elviten have commented their difficulties on the specific experiments regarding electrified L-category vehicles in the urban transport system. The project INCIT-EV has focused its presentation on the constraints of Charging infrastructures.
- the first part of the webinar was intended to give a very selected display of main results of STEVE projects from the perspective of the public authorities and the scientific/technical partners. These two perspectives are working with a different approach and mission towards the same explorative scenario.

The Light electric vehicles are evaluated from the user, the industrial and public management perspectives, returning very promising feedback on the design and the user acceptance but also doubts regarding the right and sustainable scenario for implementing new and dedicated services and infrastructures.



POLITECNICO  
DI TORINO

# STEVE PROJECT

## Fact Sheet



STEVE's goal is to show the importance of the integration of light electric vehicles into the urban transport system. Its main idea is to implement and test a "human-centric" approach towards electro-Mobility-as-a-Service (eMaaS) in heterogeneous case study

The project is led by INFINEON Technologies Austria (IFAT) and is carried on by 21 partners from 7 European countries. Four pilot testing experiences have targeted heterogeneous users and use cases.

Steve project is supported by the H2020 programme with a grant of nearly 7,5 million Euros. It imply 6 main set of activities:

- Definition of scenarios Urban e-Mobility as a Service:
- Infrastructure services connecting the smart city: B2C and B2G services
- In-vehicle and specific B2B services of e-mobility
- Deployment of selected urban e-mobility services within involved cities
- Assessment of user experience and EL-V performance
- Recommendations and policies for improved user experience and interoperability, dissemination and exploitation of the results

More information on our website: <http://www.steve-project.eu/>



POLITECNICO DI TORINO

## Introduction

Cars and lorries drive along streets, while bicycles and scooters jostle for space. Nowadays, congestion and air pollution are a recurring problem of urban living; and there is also a great economic impact due to lost time, wasted fuel and increased cost of doing business. Today 74% of the European population lives in cities and by 2025 it is expected that 21% of the EU population will be over 65 years old, increasing to 27% by 2050.

STEVE brings together cities, industrial companies, small and medium enterprises, and academic institutions from seven European countries, for the demonstration of the integration of EL-Vs (Electrified L-category Vehicles) in the urban transport system.

The STEVE project intends to maximise the impact of the demonstrations in different European cities, generate vital data for the next generation of EL-Vs and support the mind-shift necessary for a successful integration of EL-Vs in the urban transport system.

STEVE focuses on mature, advanced cities of medium size as they are the most promising type to experience a strong increase of new mobility services and solutions in the near future, while these developments are already establishing themselves in Megacities.

STEVE runs four demonstrations in four different STEVE cities. Since each city has a different focus and differs in its objectives, a common methodology framework, which covers these prerequisites will be established. The Assessment Plan will inherit concepts from established methods and other EC projects, to derive a common method tailored on the objectives and needs of STEVE. The STEVE demonstration activities are based on a stepwise approach in order to realize its set of objectives. Two iterations are foreseen to learn from the experiments and apply the corrective actions along the course of the project.

The scientific and technical objectives as well as the specific objectives of the STEVE cities affect different impact categories, namely environment, user behaviour and mobility. STEVE's main objective is to integrate EL-Vs in the urban transport system and in this framework STEVE's principal main objectives are: to detail market analysis on EL-Vs and related services; to implement new energy-efficiency and customer -oriented services for EL-Vs; to demonstrate the wide range of EL-Vs typologies and services; to analyse the operation of EL-Vs in real scenarios and work on policy recommendations.





## OBJECTIVES OF THE STEVE WEBINAR

The webinar *Scenarios of electro-mobility: cross-fertilization and dissemination of best practices and researches within EU policies* was organized in the framework of STEVE project and was an opportunity to debate, together with selected representative experts from the main European research experiments, on three crucial topics:

- Electric vehicle user centric design
- Experiments of electrified L-category vehicles in the urban transport system
- Charging infrastructures

The occurrence of pandemic restrictions lead the committee to exploit tools for a virtual debated and the possibilities to engage a broad audience also in the following up of the event. All presentations and video recordings of the STEVE webinar can be found on the project dedicated webpage: <http://www.steve-project.eu/index.php/en/resources/events-videos?webinar-may-28.-2020>

### Topics addressed

The main issues and topics addressed during the conference are the following:

- STEVE project and its main results
- Users centric e-design for innovative technologies and services
- Policy recommendation for electro mobility

### Target audience

Given the purpose of the STEVE webinar, and in light of the several topics addressed, this event did not only focus on the mobility sector but targeted more generally all relevant stakeholders involved in the different topics addressed by the STEVE approach (urban transport system; energy efficiency; customer-oriented services; policies, etc.), and thus contributing to enhance the dialogue among these key players. The webinar invited to speak researchers, practitioners, public officials, technical companies and opinion leaders in order to hopefully get a profitable mutual contamination of opinions and point of views



**POLITECNICO  
DI TORINO**



## HIGHLIGHTS OF THE WEBINAR, SESSION PER SESSION

### WELCOMING SPEECHES



**Mr Massimo VIOLANTE**

*STEVE project coordinator for the Polytechnic of Turin.*

Mr. Massimo VIOLANTE opened the webinar, as lead representative of the Italian project partners and scientific hosting partner of the webinar. The STEVE project is a complex project to implement; it is a real engagement. An efficient urban transport system is not to be seen as an end but as an opportunity. The energy efficiency issue is an opportunity to go further by acting on urban mobility, customer-oriented services and by generating economic activities. It is important to recall this global and systemic perspective. Thanks to the webinar the audience can understand the potential of shared mobility since the webinar's goal is to explain how electric vehicles and every service connected to them can be introduced in our daily life.



**POLITECNICO  
DI TORINO**





**Mrs Maria LAPIETRA**

*Mobility Councillor, Turin Municipality*

Mrs Maria LAPIETRA wasn't live during the webinar: she sent to the attendees a video to share her contribution to the webinar. After welcoming the participants to the webinar, Mrs. Maria LAPIETRA started by presenting the effect of COVID-19 on public transport and how this event can change people's mobility lifestyle. After the pandemic crisis, people will change their way of thinking, hence preferring cycling or electric vehicles instead of normal cars. There are two main reasons for that: safety and low prices compared to their own vehicle. Government has to promote this new approach to mobility and as a concrete example on how the Municipality of Torino is operating towards this, Mrs LAPIETRA presented the extensions of the bike lane. Turin is going to build 95 more kilometres of bike lanes.



**Mr Diego CIPOLLINA**

*STEVE Partner, Venaria Municipality*

After welcoming the participants to the webinar, Mr. Diego CIPOLLINA started by explaining the importance for the City of Venaria to reduce pollution, private car usage and improving safety and the importance of the STEVE project to achieve these results.

STEVE is part of a big project about sustainable mobility that the City is developing to increase citizen's welfare. Indeed Venaria Reale has been making an effort to decrease the air pollution, to improve the safety of the roads and finally to reduce private car use. Currently the City is realizing very important projects: the installation of EV charging columns; the redevelopment of a cycle lane to facilitate the way to Turin, to the Reggia and other border towns; the building of a new stretch of a cycle lane to facilitate the way into Torino city and to other nearby towns. Furthermore many projects, for instance the Vivo project, were implemented together with the other cities to promote sustainable mobility, especially the use of bicycles also by commuters. Another important infrastructure for sustainable mobility the is Movicentro project, which is being built to create an important hub to promote a smart use of the private car, of the bicycle, of the train, of the bus and of the taxi to reach Torino, the towns in Valle di Stura and Torino airport (Sandro Pertini Airport). During the COVID-19 health emergency a new challenge has arisen. Sustainable mobility themes become even more urgent, so all the towns have to be more aware of the need to improve this different kind of mobility. The webinar is really important for us to share all experiences and the results that each partner has reached.



**POLITECNICO  
DI TORINO**

## WORKING SESSION I - STEVE PROJECT AND ITS MAIN RESULTS

This first session aimed to introduce the STEVE project concept as well present the objectives, methodology and expected results. This session also intended to highlight the challenges and opportunities of STEVE through concrete examples, the DEMO: Demonstration in four different towns to demonstrate the main objectives of the project.



### The STEVE project



**Mr Johann MASSONER**

*STEVE Lead Partner, Infineon Company*

Mr. Johann MASSONER presented the project to audience in a nutshell.

STEVE is the acronym for Smart-Taylored L-category Electric Vehicle demonstration in hEterogeneous urban use-cases. The project started in November 2017 and will end in October 2020 and it involves 21 partners from 7 different countries.



**POLITECNICO  
DI TORINO**

Its total budget is € 9.517.870,18 and the activities are split into seven work packages.

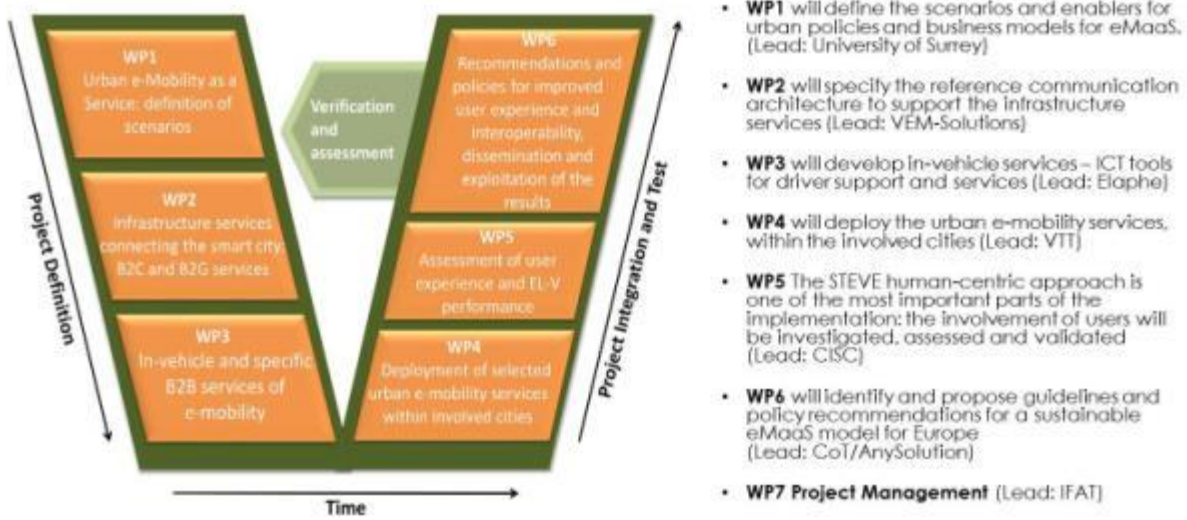

To conclude Mr. Johann MASSONER added a focus on the DEMO sites to outline the involvement of the cities.

City	Turin (CoT) + Venaria (CoV)	Villach (CoVIH)	Calvià (CoC)
Why?	To attract new potential customers (who would not normally drive M1 vehicles) to L6e/L7e vehicles	To extend the pool of EL-V users to people who would normally drive M1 vehicles to commute	To encourage eco-friendly tourism-related transport and business
Who?	Young and elderly people; tourists	Citizens, Commuters (eg. IFAT employees)	Tourists and touristic operators
What?	New low-cost 3D-printed attractive quadricycles	2-wheel EL-V and quadricycle sharing	Connectivity to infrastructure
Where?	Between railway stations and Polito; between Porta Susa railway station and the Royal Palace of CoV; between Polito and the Magneti Marelli plant in CoV	Between the city and IFAT site	Passeig de Calvià and other tourist-oriented locations



POLITECNICO DI TORINO

## SmartMobility in SmartDestinations: STEVE pilot in Mallorca



**Mrs Dolores ORDÓÑEZ**

*STEVE Partner, AnySolution S.L.*

The two cities Calvià and Palma (Spain) involved in the STEVE project DEMO are tourist destinations, therefore, to increase smart mobility they would implement electronic vehicles in the municipalities to promote sustainability.

To do that they needed to implement urban and rural routes for e-bikes in different part of the island. The Objectives as well as the achievements of the pilot are highlighted in a presentation slide.



Within the project a navigation APP "SAMAY App" was developed to guide the tourist and municipal users with an optimum speed profile, an optimization of energy consumption and by creating a gamification system with ranking & rewards



**POLITECNICO  
DI TORINO**



The SAMAY App developed as demo is now available in the play store.

In Palma a big campaign has been launched to promote plastic-free bottles correlated to the sustainable mobility to engage people not only to understand that vehicle pollution has to be taken into account but also every problem correlated to plastic materials pollution.

The correlated activities assigned to the two Cities can be presented as follows:

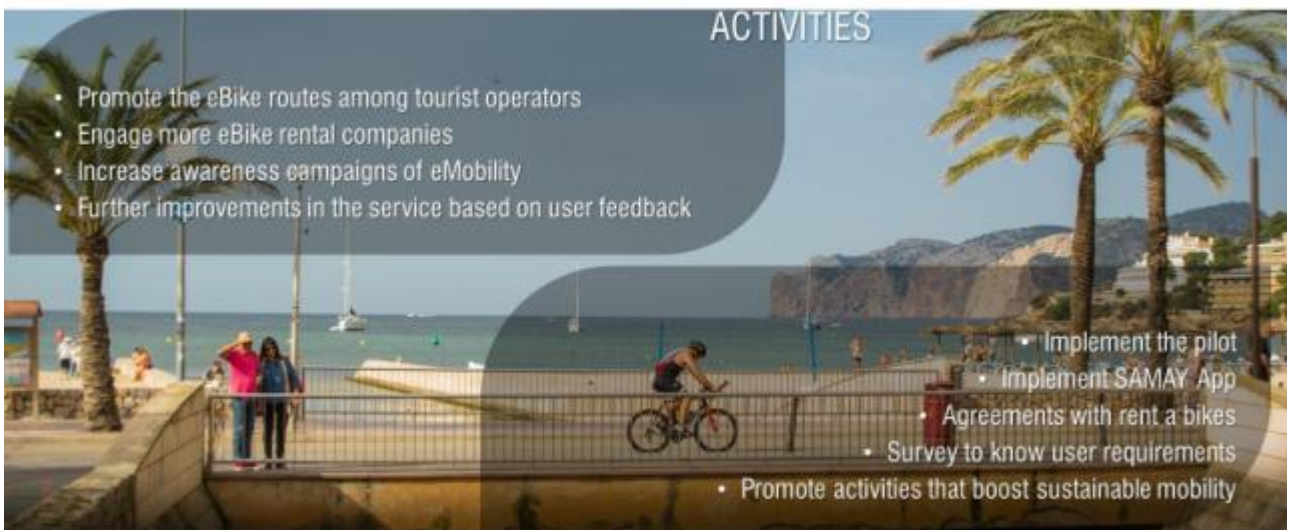

## MaaS Mobility As A Service



**Mr Maurizio VERONESE**

*5T, City of Torino in house company*

Mr Maurizio VERONESE works for 5T, a local government-owned company aimed at supporting the local authorities in the governance of smart and sustainable mobility. 5T is totally owned by local authorities; its shareholders are:



5T coordinates the local strategic programmes aimed at enabling Mobility as a Service (MaaS) paradigm in an open eco-system for the urban and metropolitan area of Torino and for the whole Piedmont region.

MaaS correlated to electric mobility can promote sustainability reducing pollution. The key aspects of Mobility as a Service are:

1. One single digital mobility app
2. A single platform which integrates multiple features and with a single payment system
3. Personalised, accessible on demand, able to meet any mobility needs
4. Able to offer a real alternative to car ownership.

The goal is to transform the actual fragmentation into an integration program that will include all the EL-Vs

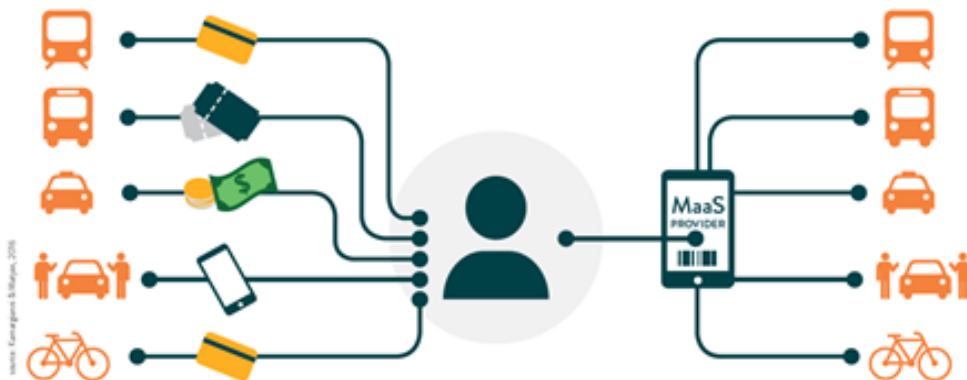

Maas system previews five levels of integration toward which five benefit and goals are correlated



With the last level of integration people could easily move from public transports to an e-bike without changing app on their smartphones.

A really powerful improvement in the structure of public mobility can happen with the MaaS structure.



## IMOVE

The IMOVE project is the first one implemented in the City of Turin. It started in 2017 with a duration of 30 months and the participation of 15 organizations (8 countries).

5T and the City of Torino did some tests principally on two pilot projects. One in collaboration with General Motors, adopting real workers, and the other one involving citizens in using a real tool to promote sustainable mobility with the objective of increasing the usage of public transportations instead of private cars.

Through the IMOVE App users have the opportunity to easily execute all the steps needed to rent an EV or use Public transport (plan, book, pay and validate) while the app collects anonymous data about the usage and launch gamification programs to stimulate its utilisation by users.

Mobility vouchers (estimated launch October 2020) and BIP for MaaS are two of the future projects that will be implemented to increase the usage of sustainable mobility.



**POLITECNICO  
DI TORINO**

## STEVE pilot in Villach



**Mr Matthias FELSBERG**

*STEVE Partner, Villach Municipality*

The focus of the presentation is on the STEVE quadricycle vehicles and the STEVE e-bike sharing service that is offered through the Steve App.

There are only three station points for cars including e-bikes in Villach, but they are going to increase the quantity during years.

### **CityApp**

Through the App, cars can be easily unlocked without using keys. Moreover, the City will implement also the CityApp to give to users integrated services connected to the vehicle such as to promote stores, parking, gamification etc...

With the usage of sustainable mobility, the City of Villach is trying to improve the knowledge of citizen but also to change tourists' mentality about the usage of electric vehicles.



**POLITECNICO  
DI TORINO**



## City of Venaria perspectives to develop Maas system



**Mrs Roberta CARDACI**

*STEVE Partner, Venaria Municipality*

The City of Venaria is an important historical city. In the La Mandria Park there is the Royal Palace named Reggia di Venaria which was one of the royal palaces preferred by the Savoy family.

Nowadays Venaria Reale is one of the most visited sites in Italy with more than 10 million visitors, since 2007.

Because of the presence of huge parks and rivers, the city of Venaria is a perfect location to implement sustainable mobility.

### RESULTS AND MAIN ACTIVITIES

#### OBJECTIVE MEASURE FOR SUSTAINABLE MOBILITY IN VENARIA REALE

1. TAKE PART TO THE IMPLEMENTATION OF NEW SUSTAINABLE MOBILITY PLAN OF THE METROPOLITAN AREA
2. PROMOTING AND IMPROVING PUBLIC URBAN TRANSPORT SYSTEM
3. INTRODUCING TRAFFIC CALMING ACTIONS AND 30 ZONE STRATEGY
4. FOSTERING CYCLING AND WALKING TO SUPPORT WELLNESS
5. EMPOWER PARKING MANAGEMENT
6. EMPOWER TRAFFIC MANAGEMENT TO IMPROVE AIR QUALITY AND REDUCE NOISE
7. SUPPORT ELECTRIC MOBILITY AND MICRO MOBILITY
8. SUPPORT SHARING PHILOSOPHY
9. IMPROVE ACCESSIBILITY TO THE HISTORICAL VALUES OF THE CITY WITH GREEN MOBILITY FOR ALL INCLUDING ELDERLY AND DISABLED PEOPLE
10. PUBLIC CAMPAIGNS TO PROMOTE SUSTAINABLE BEHAVIOUR ENGAGING STAKEHOLDERS TO ACTIVATE ALL TOGETHER

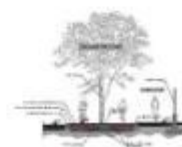

### MoviCentro

"MOVICENTRO" is an innovative hub to support green mobility now under construction with the support of Piedmont Region – with a budget of 4.900.000 euros. It is one of the main stations on the metropolitan railway system connecting the centre of Turin with the UNESCO sites and the airport.



**POLITECNICO  
DI TORINO**



Movicentro ensure multi-modality in the same place: in two years the trains SF2 (TURIN – AIRPORT LANZO VALLEY) connecting Venaria with the main Station of Turin in 15 minutes passages every 15 minutes acting like a light metro: this will change CITY mobility assets



One of the most important goals achieved is the MoviCenter that considerably improves green mobility, by ensuring a transport connection between Venaria and Turin and to Caselle Airport.

### Results

The main results that the City of Venaria achieved are the bus line rationalisation and bus stop empowerment, when in 2018 there was the introduction of electric buses, the implementation of electric bikes and cars sharing and a selection of 30 zones and paths near parks and schools.

In the last 2 years the City of Venaria activated a competitive procedure to install and manage charging stations for electric vehicles. Ten companies expressed the willingness to join and follow all the bureaucratic aspects to then install 31 charging stations to serve 62 parks.

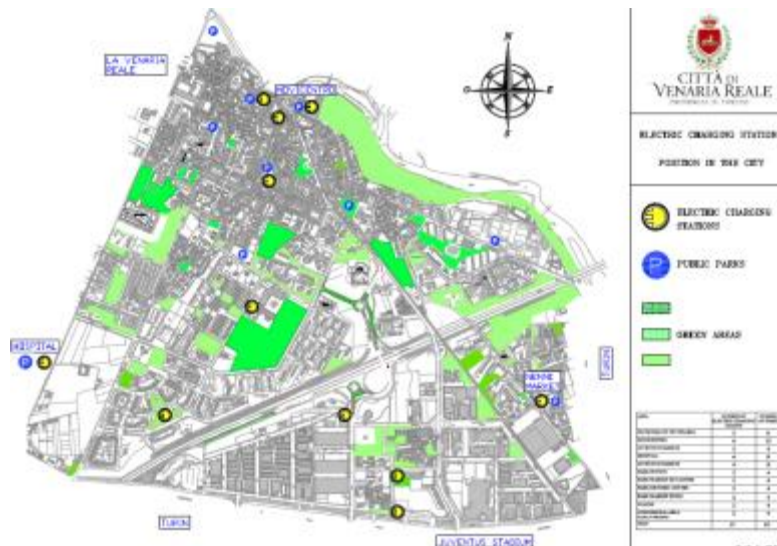

POLITECNICO DI TORINO

Moreover, with the Steve project the City of Venaria implemented electronic gates to control the accessibility in the city but also the usage of the EV.

With the project VIVO the City helps users to approach sustainable mobility with some monetary incentives in buying e-bikes.

**VIVO : Via le Vetture dalla zona Ovest di torino**  
 PUT Away the cars from the West Zone of Turin.  
 2017, 7<sup>th</sup> national competition

**VIVO**  
 Living in the West Zone of Turin

**CONTRIBUTION TO BUY CYCLE**

**Contributo di 100 €**  
 per l'acquisto di biciclette a pedale elettrica

**ELECTRIC CYCLES**  
 ✓ Budget: € 45,000  
 ✓ Call zone available  
 ✓ Beneficiary: residents and workers in Zone Ovest

**Una proposta che fa una piega.**

**BIENTRACCE** (bidding bikes + bus pass for public transport)  
 ✓ Budget: € 45,000  
 ✓ Call zone available  
 ✓ Beneficiary: residents and workers in Zone Ovest

**BICI X TUTTI**

**BICI FOR ALL**  
 To buy cycles, mopeds, segways, tandem, handbikes  
 ✓ Budget: € 45,000  
 ✓ Call zone available  
 ✓ Beneficiary: residents and workers in Zone Ovest

The challenges, over 10 years, will be to support electric mobility in order to reduce pollution and to introduce the possibility for every tourist to use EV to visit all the UNESCO sites.

**CHALLENGE FOR THE NEXT 10 YEARS  
 (S.U.P. METROPOLITAN CITY OF TURIN ACTIONS)  
 MEASURE FOR ELECTRIC MOBILITY IN VENARIA REALE SUPPORTED BY THE STEVE EXPERIENCE**

**1. SUPPORT ELECTRIC MOBILITY AS ONE OF THE BEST ACTION AGAINST TRAFFIC POLLUTION AND NOISE:**

- develop the infrastructure by improving coverage of charging areas both in private and public spaces
- empowering all the electric sharing system with the metropolitan area
- supporting dissemination of best practices
- joining others initiatives to support the investments.

**2. BOOSTING ELECTRIFICATION IN WASTE COLLECTION SERVICES AND TRANSPORTS**

**3. INTRODUCING THE POSSIBILITY FOR ALL TOURISTS TO USE EL Vs and electric micro mobility to visit the UNESCO SITES that have an extension of 3 km, 6 km including the whole park**



**POLITECNICO  
 DI TORINO**

## WORKING SESSION II - USERS CENTRIC E-DESIGN FOR INNOVATIVE TECHNOLOGIES AND SERVICES

The second working session was specifically dedicated to stimulating audience to engage toward a user-centric and e-design approach for innovative technologies and services.



### Users centric e-design for innovative technologies



**Mr Daniele BARANZINI**  
*STEVE Partner, Ospedale San Raffaele*

The presentation starts with a box showing the composition of the project team created to achieve the project goal of “Users centric e-design for innovative technologies”.

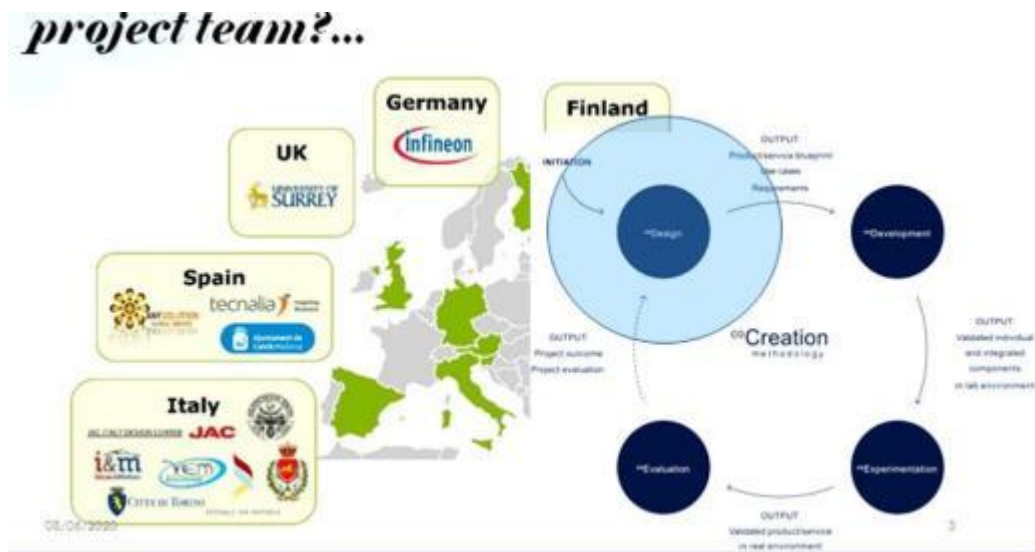

**POLITECNICO DI TORINO**

The Ospedale San Raffaele (OSR) was in charge, in the STEVE project, on a mass quantity of surveys to get as much information as possible to try to answer to the question "What do our users need and want?". The method was:

- Market Analysis
  - Market mining
- STEVE Survey (user)
  - Profiling next gen Users
- Forum - (user)
  - Knowledge mining

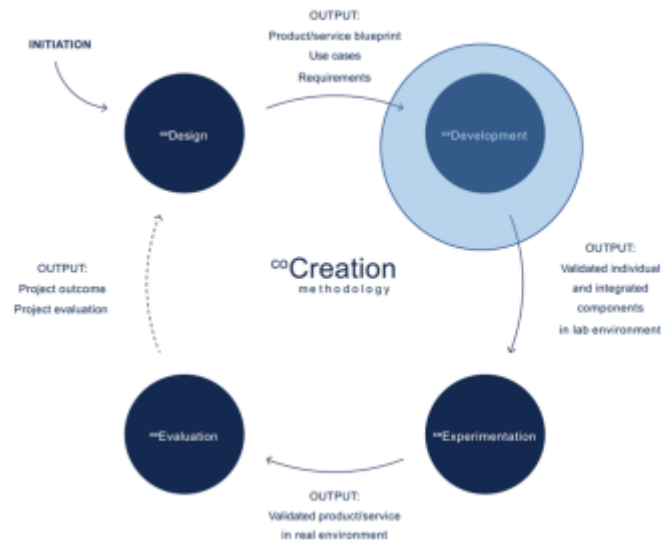

The targets were: Residents, commuters (someone that regularly travels between work and home), Business travellers, Leisure travellers and tourists.

Key areas for the experimentation were in Italy (Turin and Venaria Reale), Spain (Calvià) and Austria (Villach). With more than 4000 participants in total.

Users completed surveys before, during and after hiring the EV, to analyse some important aspects shown in the picture below:

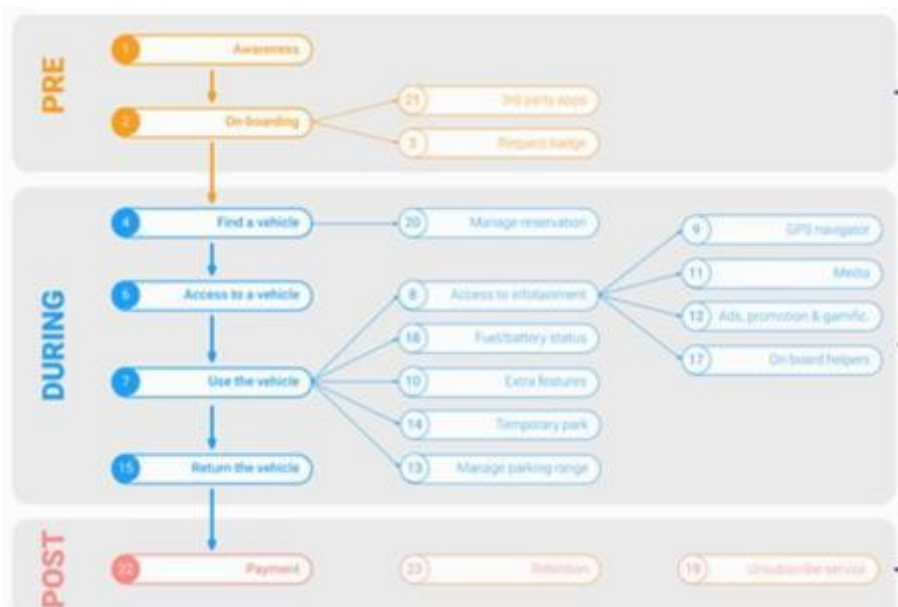

POLITECNICO DI TORINO

Scope of the survey was to achieve the following survey objectives:

- How familiar are users with Electric Cars, e-Bikes, smartphone payments and preferred type of payment?
- What are the user needs regarding mobility?
- How could STEVE EL-V help users?
- Etc...

The main results achieved are:

- Shared mobility services and gamification
- key type of reward (free ride after 10 rides made)
- Sharing your information on your "mobility" behaviour is less accepted in Villach and favoured in Turin.
- The top key factors: "the distance to pick-up station" for Villach, and "free parking when using a shared vehicle" both in Torino and Calvià.
- "Booking with a smartphone app with registration" is the most preferred modality

These tests were the opportunity to understand that sustainable mobility will be based on citizens' preferences (not only market driven). The ethical City Marketing Campaigns related to green e-Mobility have to target early adopters, and municipality campaigns have to target laggards only (cost savings). Another target was to rapidly estimate the fleet maintenance costs and utilization.

### Technical developments on energy-efficient torque-vectoring and speed profiling



**Mr. Aldo SORNIOTTI**

*Steve partner, University of Surrey*

The topic presented by Mr. Aldo SORNIOTTI is the technical analysis of Active safety enhancement of electric quadricycles and the energy efficiency of the vehicles.

In the past there was a very important debate about the safety of these electric vehicles also shown in the Italian magazine "Quattroruote" because of the wheel lifting under particular conditions.

The first goal of the Steve project is to improve this safety aspect utilizing the Torque-Vectoring Control, which means that it not only can a traction force but also a different value of longitudinal force be generated on the two sides of the vehicle to better control its own stability.

Looking at the energy management objective set by the Steve project, the University of Surrey tried to use the Torque-Vectoring Control also to improve these aspects. Positive results appeared. Due to the



**POLITECNICO  
DI TORINO**

Torque-Vectoring Control an actual reduction in power loss correlated with the increasing lateral acceleration was revealed.

In the picture below an example is shown of nominal energy-efficient reference yaw rate profiles as functions of steering wheel angle, for different values of vehicle speed and longitudinal acceleration.

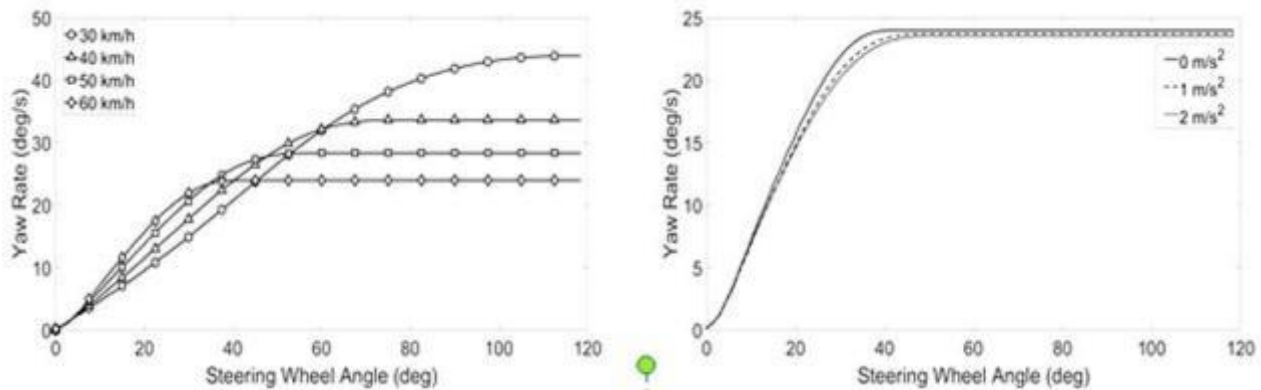

Moreover, the development of an implicit nonlinear model on predictive control technology for energy-efficient torque-vectoring can be reproduced analysing a simple cost function considering the internal model and the constraints related (max and min vector-torque).

Cost function  $\min_{\mathbf{u}} J_n(\mathbf{x}(k), \mathbf{u}(\cdot)) := \sum_{k=0} \ell(\mathbf{x}(k), \mathbf{u}(k))$

s. t.

Internal model  $\mathbf{x}(k+1) = f(\mathbf{x}(k), \mathbf{u}(k)), \quad k = 0, \dots, N-2$

Constraints  $\underline{\mathbf{x}} \leq \mathbf{x}(k) \leq \bar{\mathbf{x}}, \quad k = 0, \dots, N-1$   
 $\underline{\mathbf{u}} \leq \mathbf{u}(k) \leq \bar{\mathbf{u}}, \quad k = 0, \dots, N-1$   
 $\mathbf{u}(\cdot) : [k, k+N]$

Adaptation of the cost function weights depending on the driving situation

$$\ell(\mathbf{x}(k), \mathbf{u}(k)) = \underbrace{W_{u,F_x} \{F_{x,ref} - [F_{x,FL} + F_{x,FR} + F_{x,RL} + F_{x,RR}]\}^2}_{\text{Blue line}} + \underbrace{W_{u,\psi} [\dot{\psi}_{ref} - \dot{\psi}]^2}_{\text{Red line}} + \underbrace{W_{u,\alpha_R} \alpha_R^2}_{\text{Yellow line}} + \underbrace{W_{u,PWT} P_{Loss,PWT}^2}_{\text{Light blue line}}$$

$$+ \underbrace{W_{u,Tire} [P_{Loss,Tire,Long} + P_{Loss,Tire,Lat}]^2}_{\text{Green line}} + \underbrace{W_{u,LD} \left[ \frac{\tau_{RL}}{\tau_{FL} + \tau_{RL}} - T_{r,ref,L} \right]^2}_{\text{Violet line}} + \underbrace{W_{u,LD} \left[ \frac{\tau_{RR}}{\tau_{FR} + \tau_{RR}} - T_{r,ref,R} \right]^2}_{\text{Violet line}}$$

- **Blue line:** represents the target of tracking the reference of torque demand
- **Red line:** represents the target of tracking the reference of energy efficiency rate.
- **Yellow line:** represents the vehicle safety and stability
- **Light blue line:** represents the power loss terms
- **Green line:** represents the power of longitudinal and lateral tires leaks
- **Violet line:** represents optional term that can be considered

The development of a nonlinear predictive model control technology for energy-efficient torque vectoring will be tested after the COVID-19 lockdown with a dynamic simulation, analysing the



**POLITECNICO  
DI TORINO**

maximum speed that the vehicle can reach before hitting the obstacle. Using the torque-vectoring method the maximum speed could be increased thanks to the improvement in stability.

The steps to obtain diminishing energy consumption are:

1. Brute force simulations
2. Optimise simulations with Dynamic Programming (DP)
3. Design of energy-saving controller
4. Experiments to test controller

The goal is to obtain the best optimal speed mixed with the torque-vectoring angle acted with the Pulse-and-Glide. PnG reduces energy consumption in low speed conditions.

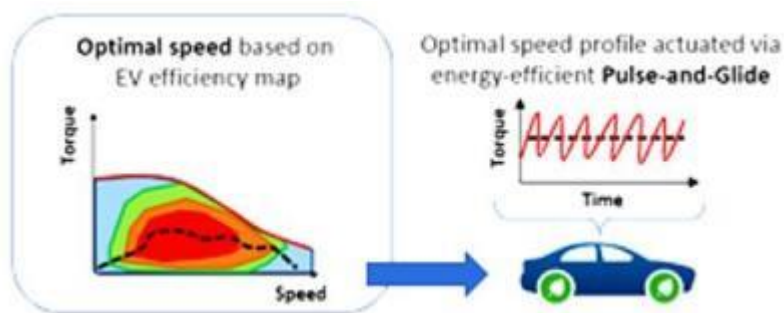

### Are we entering in E-GO AGE?



**Mrs. Xu Meihua**

*STEVE Partner, JAC – Italy Design Centre s.r.l.*

Mrs Xu Meihua begins the presentation showing a video about some future performance parameters that an EV must have in the future.

She continues analysing that as we are in the E-GO age with 300 years of energy consumption, pollution can be considered one of the main issues of today and humanity needs to change habits to survive.

The Steve project can stimulate the knowledge of people in understanding the importance of changing transport mobility. With E-Mobility there would be investments mainly in Aesthetic Design (to improve inside spaces, vehicle structure and colours), Advanced Technologies (using digital intelligence at the expense of mechanical usage in order to increase safety) and Sharing Mobility (EV is not a property but a service, to reduce private vehicles, noise and pollution) aimed to achieve market acceptance.

E-GO: The mission is to switch from E-GO to a revolution achievable with the Steve project to obtain a new generation style of mobility.



**POLITECNICO  
DI TORINO**



## Users services scenarios



**Mr Markus PISTAUER**

*Steve Partner, CISC Semiconductor GMBH*

Mr Markus PISTAUER first analysis is on “how provide access to e-mobility infrastructure and related services for users?”. Mr. Markus PISTAUER explains that one of the first necessary prerequisites is to give the possibility to everyone to charge their own vehicle. Moreover, thinking about stakeholders, we do not consider many of them.

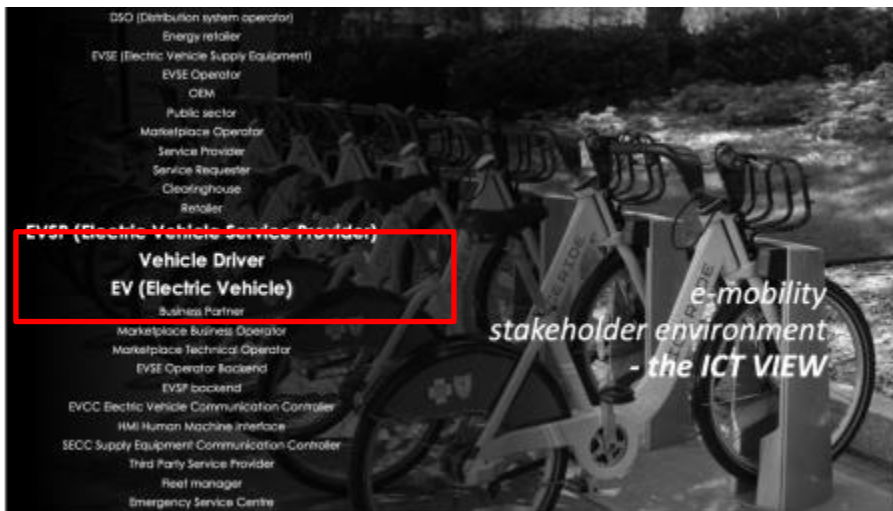

In red, the ones normally considered, above and below the ones normally not considered. This means a complex environment around e-mobility. Then follows a new way of charging vehicles to improve parking stations. Two charging pools (at two addresses) consisting of two/three charging stations each.

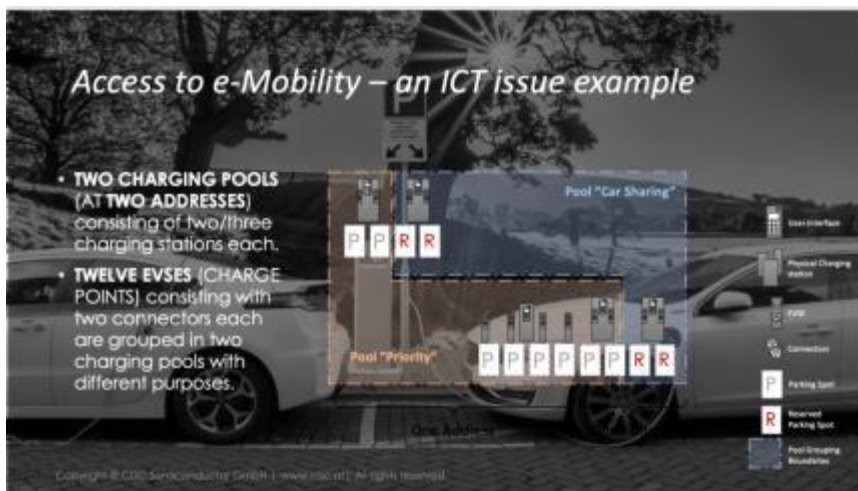

Twelve EVSEs (charge points) consisting of two connectors where each one is grouped in two charging pools. Users can gain priority by paying a fee or by receiving a reward to have the possibility to charge the vehicle faster.



**POLITECNICO  
DI TORINO**

Which tools can be used:

1. Automatic identification of driver or car (tariff model selection and charging mode selection)
2. Up-front reservation to move faster (fast charging can be pre-reserved)
3. Online and Offline MODE
4. Instant updates to your SMARTPHONE (charging status and near services. e.g. Coffee, local mobility)
5. Payment, Fleet / Carpool management (e-MaaS platform, company or rental cars)
6. 3<sup>rd</sup> party access (interact with and benefit from local infrastructure. e.g. Garage charging)
7. Seamless integration into existing platforms.

e-Charging is the App that can be used to see all of these tools mentioned before, but every info will also be in the Steve App.

### Telematics: enabler for vehicular MaaS



**Mr. Marco ANNONI**

*STEVE Partner, VEM Solution S.p.A./Viasat Group S.p.A*

Telematics is a set of interdisciplinary technologies that are providing automotive industry tools, methodologies and systems to transform driving into an engaging and interactive connected vehicle user experience.

EV is considered as a service providing a lot of information about users. This information has to be extrapolated and used to provide increasingly better services. To measure all this information a telematic box was created to send all the information to a TSP (Telematic Service Provider) Control Centre as we can see in the orange box below.

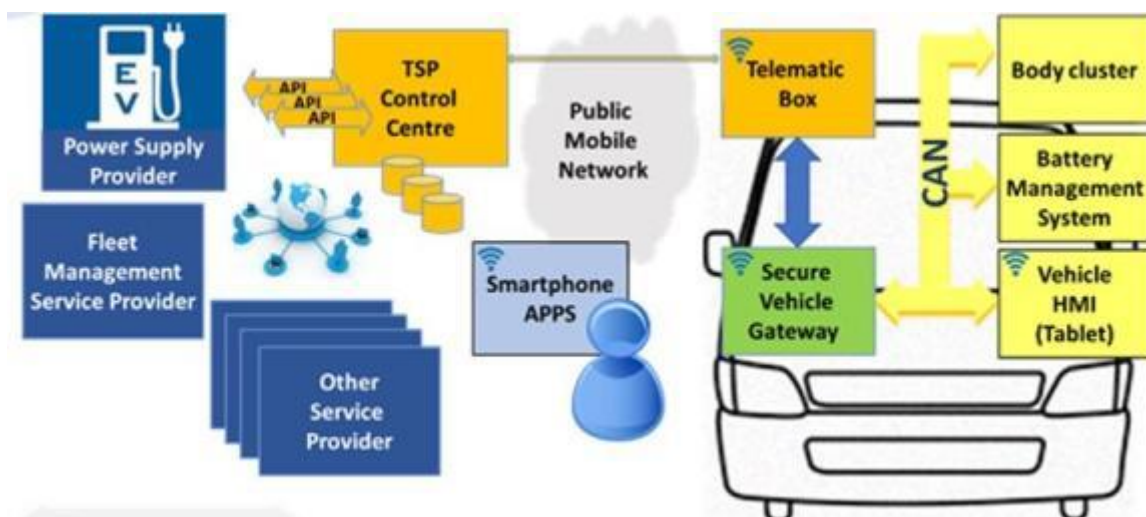

In detail the service Domains and who was in charge of them.

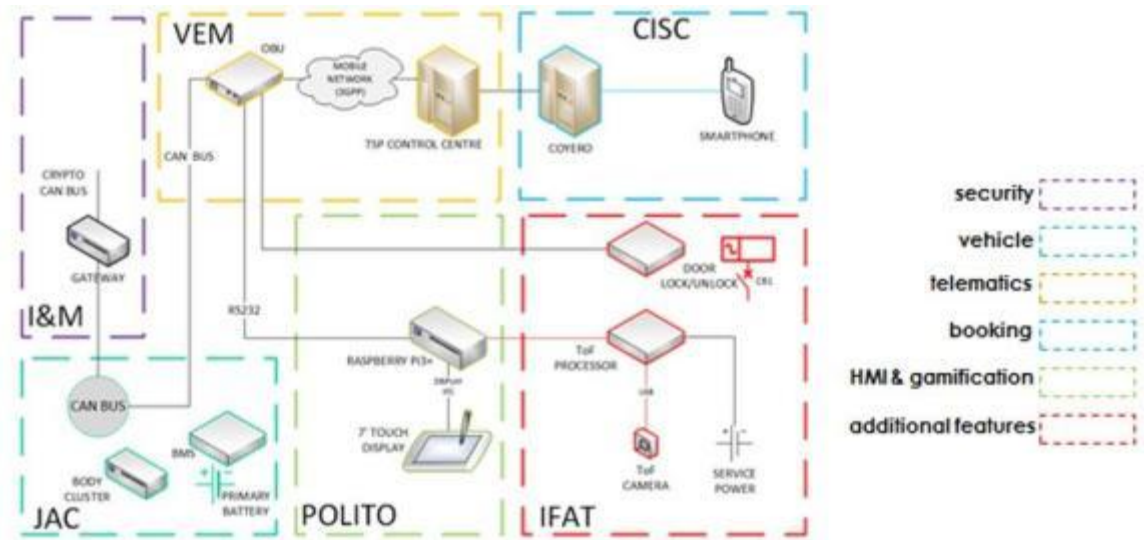

All of the above boxes are prototypes and have to be tested. The data of TPS Control Centre could be considered really important to:

- Receive data coming from vehicles.
- Store data for post processing & analysis.
- Provide vehicle tracking & event monitoring.
- Vehicle trip history.

Due to COVID-19 VEM stopped tests sessions on some prototypes (e.g. Steve Obu, Secure GW or Steve HMI etc...) but some of them were already developed and ready to become a commercial device as soon as this emergency will slow down.

### Communication & Gamification



**Mr. Massimo VIOLANTE**

*STEVE Partner, DAUIN Department of Automation and Computer Science, Polytechnic of Torino*

Communication has to be the main point to address, showing the benefit of LEV usage in the cities, to decrease trips costs compared to normal vehicles and also CO<sub>2</sub> emissions. Engaging users is one of the main issues and for this purpose gamification can be considered an active part of the project. An example of communication can be, as we can see in the picture below, the blue indicator which shows the remaining energy power that visually helps users to understand their battery status.



**POLITECNICO DI TORINO**



The system also calculates, compared to the driving style, the amount of kilometres that users can still do before running out of energy.

In the green box it is possible to see the energy cost in euro compared to the Gasoline cost, so, as mentioned before, the cost saving and also the CO<sub>2</sub> saving in Kg. Moreover, based on the driver's own driving style (battery consumption) the leaf on the right remains green if the driving style is "Very Good", becoming yellow if it is "Fair" or red if it is "To Be Improved".

The gamification program works connected to the App reporting gas emissions and gives free trips if the user's driving style is "Very Good". Using this methodology, one can increase the awareness in users that using EV could drastically diminish gas emissions.



- Implemented in the mobile app used for vehicle booking
- Each user gets a score based on CO<sub>2</sub> and cost savings
- Scores accumulate and can be redeemed as free trips

### Gamification

## Innovation in automotive devices for electro mobility



**Mr. Riccardo GROPPA**

*STEVE Partner, Ideas-Motion S.r.l.*

A wide range of technologies are under development within STEVE, to be integrated into the EV-Ls and aimed at improving the user's experience.



**POLITECNICO  
DI TORINO**



## WORKING SESSION III - POLICY RECOMMENDATION FOR ELECTRO MOBILITY

The second working session was specifically dedicated to stimulating a debate on policy advice to create and administer public policy of the ongoing work on sustainable mobility by government managers.



### INCIT-EV H2020 project



**Mr Paolo GUGLIELMI**

*H2020 INCIT-EV Partner Department of Energy Polytechnic of Turin*

The INCIT-EV Project starts in 2020 meeting part of the project requirements already foreseen by Steve. The Objectives are really similar to previous Steve subprojects: CREATE Innovative set of charging infrastructures, EXPLORE new high-end technologies, DRAW UP Business models and market preferences and IMPROVE the EV user experience and foster the EV market share in the EU.

This project involves 33 Partners connected in 7 countries with a duration of four years.



**POLITECNICO DI TORINO**

 <ul style="list-style-type: none"> <li>• Interoperability with electric LDVs</li> </ul>	 <ul style="list-style-type: none"> <li>• DC/DC superfast chargers</li> <li>• Electronics</li> </ul>
 <ul style="list-style-type: none"> <li>• Connection with the power network and Installation DC/DC chargers</li> <li>• V2G system deployment</li> </ul>	 <ul style="list-style-type: none"> <li>• Chargers communication modules</li> <li>• Large-scale replication plan within the city</li> </ul>
 <ul style="list-style-type: none"> <li>• Installation permission and public space availability</li> <li>• Connection With The Tramway Power Network</li> <li>• Smart And interoperable payment systems</li> </ul>	 <ul style="list-style-type: none"> <li>• Chargers Supervisor</li> <li>• Chargers prototypes, V2G and control algorithms development</li> <li>• Operations/monitoring</li> </ul>

Use case analysed:



When considering the Use case n°4 expectations are to put charging hub in a park-and-ride facility in Turin adapting the tramway substation to supply the charging hub in order to use the untapped power available.

This improvement is useful to focus on inter-modality, reducing traffic congestions and increasing the growth of the local EV market.

The Charging hub situated in Caio Mario Parking (Turin) can comprise ten bidirectional (V2G ready) low power (more than 4 hours) conductive charging points for EVs and one ultrafast unidirectional static conductive charging point (for short recharging times).

Moreover, there will be one small track unidirectional DWPT for stationary application with different type of vehicles (FABRIC EU project) and one ultrafast unidirectional static WPT charging point devoted to light vans or small busses (ASSURED EU project).

The possibility to have a common storage can be only simulated for low budget reasons.



POLITECNICO DI TORINO

Other features that have to be developed could be:

1. DSS (Decision Support System) to support mobility planners
2. Research on EV users' preferences & expectations, similar to the one seen before, speaking about the other Steve subprojects.
3. An App that can help users to match their needs.

There are some other activities that could be activated with LINKS company such as:

- Deployment and monitoring of planning applications
- Definition of the module for the estimation of impacts and costs on road infrastructures
- Chargers' communication modules
- DSS modelling (supporting the DSS system)
- Large-scale replication plan within the city
- Cybersecurity & interoperability

## QUIET H2020 project



**Mr Hansjörg KAPELLER**

*H2020 QUIET Partner, AIT Austrian Institute of Technology GmbH*

The project is coordinated by Dragan SIMIC (AIT Austrian Institute of Technology GmbH) with a total budget of 6,998,955.00 EUR with more than 13 Partners.

The motivation of this QUIET Project is to increase the usage of EVs but also to manage the thermal system. Both are fundamental to provide comfort to vehicle users. Heating and Air Conditioning systems can consume a lot of energy from the batteries.

Moreover, with cold weather conditions ( $-10^{\circ}\text{C}$ ) there will be a 60% increase in consumption of energy if users wanted to maintain better comfort conditions.

Further expectable potential improvements were classified and clustered in three different areas:

- *Area 1:* that addressed the user centric design, main topic of this project, in which a reduction in energy consumption is expected of roughly 10%.
- *Area 2:* that deals with lightweight components to optimize thermal insulation. As in the previous area the expected reduction is of nearly 10%.



**POLITECNICO  
DI TORINO**



- *Area 3:* Addresses the innovative cooling and heating techniques. In this area the energy consumption should be reduced by 10-15% and also through novel AC with PCM storage there will be a decrease of the same percentage.

For each area, project partners:

- Made an analysis and improvements corresponding to all aspects of the user-centric design of vehicles which directly or indirectly impact energy consumption.
- Developed solutions with the application of novel materials which improve the thermal insulation of vehicles and hence reduce energy consumption.
- Reduced weight and thermal inertia of systems and components in the vehicle in order to improve efficiency without reducing performance.
- Integrated advanced systems and components for optimizing both occupant comfort and energy consumption.
- Implemented and tested different solutions at vehicle's full capacity to ensure safety which is not affected by any modification.

QUIET project will adopt a new HVAC HMI approach that will be based on actual user perception and focus on human, not on technical HVAC system

As we can see in the image this is a simulation model of HVAC System development

- HVAC model structured in three parts
  - Refrigerant cycle - R290 (green)
  - Water-glycol cycles (blue)
  - Air cycles (orange)
- All HVAC components realised and ready for integration
- Possible operating modes
  - Heating
  - Cooling
  - Reheating
  - Heating with waste heat
  - Deicing
  - PTC heating

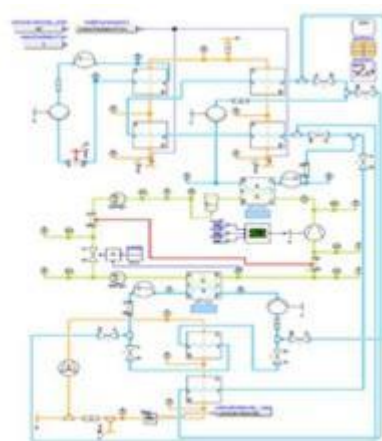

Some examples to improve the system:

- R290 EXV = a compact, highly efficient expansion valve for propane, that can be used also bi-directionally with integrated on-board diagnostic and a safety valve technology to decrease the risk of an accident.
- R290 COMPRESSOR = Cheaper compared to similar competitor refrigerants, R290 refrigerant cycle can be operated with higher COP over large temperature ranges compared to conventional refrigerants.
- PCM - PHASE CHANGE MATERIAL = The use of PCM in EVs hasn't been thoroughly explored so after testing it they will find the most suitable integration to meet the needs. QUIET won't just



**POLITECNICO  
DI TORINO**

show the possibility to integrate PCM into the thermal management of EVs but will also verify how much energy could be saved.

- LIGHTWEIGHT DOORS = Prototype shells with front and rear door panels (carbon fibre reinforced)
- LIGHTWEIGHT SEATS = Lightweight structure >15% weight reduction besides good strength

Due to COVID-19, project partners didn't finish all the tests, but until the end of June partners predefined that the vehicle will be ready to use with every tool and they would start the test.

## DOMUS H2020 project



**Mrs Ines MUÑOZ**

*H2020 DOMUS Partner, Applus IDIADA*

Total budget for the project is 8.958.010€ (100% EU contribution) with 18 international partners. Project started on November 2017 and lasts for 42 months.

Similar to another project presented before, partners intend to:

- Achieve an increase of 25% of the electric drive range of EVs.
- Generate knowhow about user's perception of comfort and corresponding cabin requirements for future mass-market oriented efficient EVs.
- Develop, integrate and demonstrate new components, systems and control strategies for EVs that are energy efficient, comfortable and safe.

The project purpose is divided in two, firstly reducing the overall cabin energy requirements and secondly making the energy as efficient as possible.

The assessment framework must be as energy efficient as possible taking into account also safety and comfort perception.

To evaluate the comfort inside the vehicle, the partners involved tried to introduce other parameters that no one had considered before such as noise, smells or lighting.

Correlated to the comfort, the partners involved tried to mix every new innovative idea or rule imposed by government to find a passenger cabin that must improve the efficiency factor but maintaining also the comfort parameter up to standard.

In the picture below it's possible to briefly see an example of this project:



**POLITECNICO  
DI TORINO**

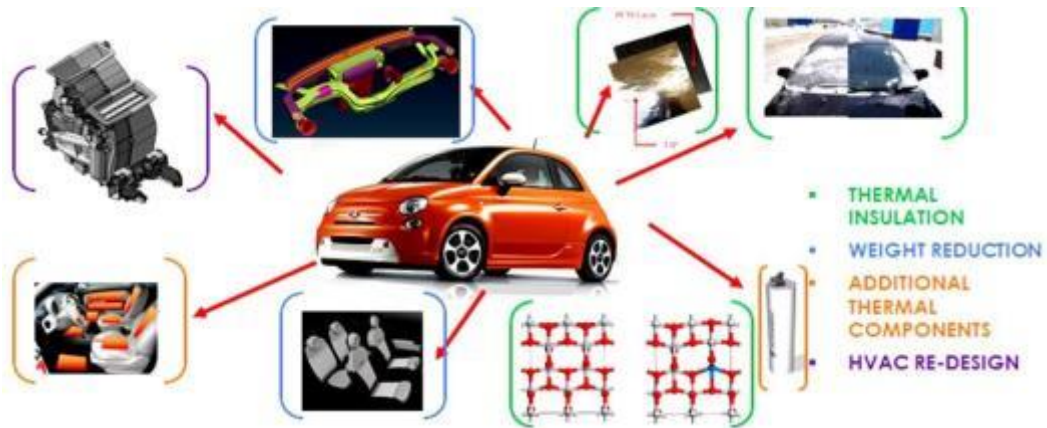

All of these features will be integrated in the demo car to be tested, in which these technologies will be adapted to different scenarios and adjusted to find out the right implementation of each tool.

The Domus timeline is shown in the table below:

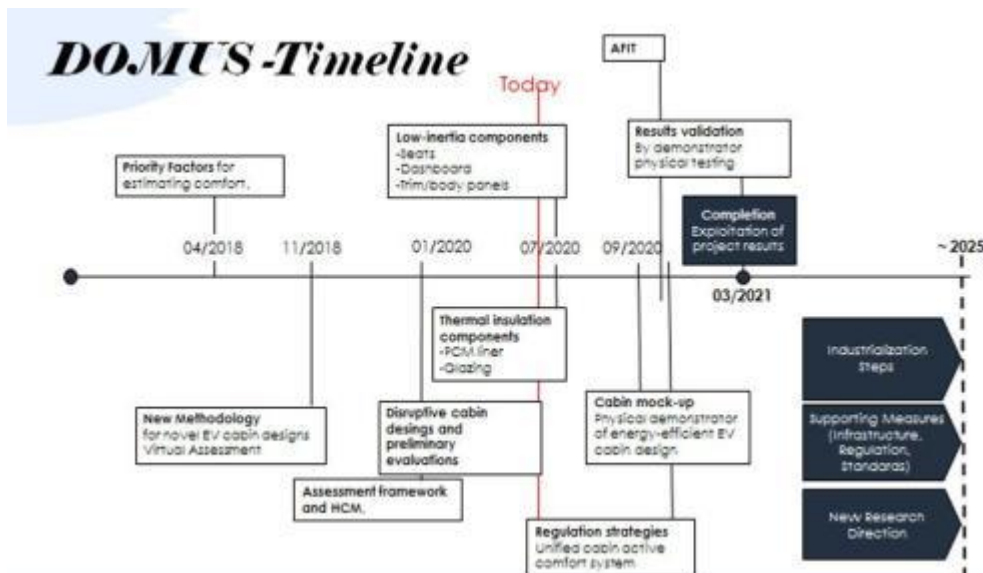

Some deadlines shifted due to COVID-19 crisis, but partners expect to restart in few months.



POLITECNICO DI TORINO

## ELVITEN H2020 project



**Mrs Christina ANAGNOSTOPOULOU**

*H2020 ELVITEN Partner, Institute of Communication & Computer Systems*

ELVITEN Project began in November 2017 lasting for about three years with the help of 21 partners from six Cities: Trikala (Greece), Bari, Rome, Genoa (Italy), Berlin (Germany) and Malaga (Spain).

### *ELVITEN at a Glance*

- **Call Identifier:** H2020-GV-2016-2017
- **Topic:** GV-10-2017 "Demonstration (pilots) for integration of electrified L-category vehicles in the urban transport system"
- **EC Funding:** EUR 7.8 million
- **Duration:** November 2017 - October 2020
- **21 partners**
- Coordinated by **ICCS (Institute of Communication and Computer Systems), Greece** . Dr. Angelos Amditis (a.amditis@iccs.gr)
- Learn more: <http://www.elviten-project.eu/>
- Join us:

This project has received funding from the EU's Horizon 2020 research and innovation programme under GA no 769926

5/28/2020 2

ELVITEN main objectives:

### *ELVITEN Objectives*

- Demonstrate in **six Cities**:
  - Different categories of **EL-Vs**
  - EL-Vs **innovative parking and charge services**
  - **Support ICT tools to facilitate the usage** of EL-Vs (Booking, Fleet Monitoring)
  - **Support ICT tools to motivate** the usage (Digital Coach app, Serious Game app, Incentives Management Smart Card)
- **Generate a Big Data Bank of trips and perceptions data**
- Analyse and create appropriate **business models and guidelines for vehicle manufacturers and planning authorities**
- **Involve Users and Stakeholders** (Follower Cities and Regional Support Groups)

This project has received funding from the EU's Horizon 2020 research and innovation programme under GA no 769926

5/28/2020 3



**POLITECNICO  
DI TORINO**

MRS ANAGNOSTOPOULOU introduces the main topic of her speech : how to integrate the electrified L-category vehicles into Transport and Electricity Networks. Different categories of EL-Vs have already been tested with the use also of innovative parking and charge services mainly with the involvement of users and stakeholders.

The Support with ICT tools can facilitate and motivate the usage of EL-Vs (Booking, Fleet Monitoring). Partners also analysed and created appropriate business models and guidelines for vehicle manufacturers and planning authorities.

Perception by public stakeholders was really good and with the first online survey they obtained 7400 responses. Users' experience with EL-Vs was very low except for Berlin users, because they were very interested in understanding the functionality and also every correlated incentive. Four kinds of EL-Vs were used: bikes, motorcycles, tricycles and quadricycles.

The ICT is used to monitor the users but also the vehicle using a specific platform that started from data extrapolated from the vehicles and represented in a dashboard. Analysts can study every dynamic and behaviour from the platform.

The main statistic data have been extrapolated evaluating:

- Vehicle's usage quantity (by distance and time)
- Problems encountered during the trip
- Trips' purposes

Results were that trip distance is normally lower than 4 km, regular users normally took the EV again after using it and that male was the predominant gender in utilizing EV with an average age of 30 to 59. Regarding the service, 90% of users were normally satisfied and the reason why they select EL-Vs were:

- to save time
- great comfort
- curiosity

During COVID-19 there has been a different change in some data, a first indicator has been a reduction in the use of vehicles and the variability in final destinations. Other values have remained more or less stable (Example: duration of the trip).

Since this project needed a high support level, a network was established of Follower Cities and RSGs with already 16 agreements with European Cities and 78 agreements with Regional Stakeholders. Due to COVID-19, they will contact cities again to collect more agreements with the interested ones.

Future project steps

- Final Analysis of real usage (mobility, parking, charging patterns) with EL-Vs, problems encountered and acceptance after the end of demonstration period in June 2020.
- Scale up the findings and estimate the potential market uptake of EL-Vs
- Prepare replicable sustainable business models
- Generate guidelines for Vehicle Manufacturers and Planning Authorities also to establish good guidelines to promote sustainability.



POLITECNICO  
DI TORINO

## INCIT-EV H2020 project



**Mr Federico BONI CASTAGNETTI**

*H2020 INCIT-EV Partner, Iren S.p.A.*

Iren is a large organisation comprising:

- About 8,000 employees, 7 M customers in our territories
- 1.7 M customers in the energy sectors
- 2.3 M customers in the environmental sector
- 2.9 M customers in the integrated water cycle
- 1<sup>st</sup> operator in Italy for district heating
- 3<sup>rd</sup> operator in Italy in the integrated water cycle
- 3<sup>rd</sup> operator in Italy in the environmental sector

Composed by various kinds of services IrenGo solution can be considered as solid reality to implement EV Projects. In the picture below a detailed explanation of the IrenGo offer.



The eVolution2G project aims to study and test, under operative conditions, Vehicle-to-Grid (V2G) devices as a solution for the electric grid balancing.

The main goals of the project are:

- to develop a light vehicle with an innovative system for the management of the battery and the bidirectional charge;
- to develop an Energy Management and Control System for the management of the data exchange between all the players involved (customers, DSO, CPO, etc.);
- to test prototypes of HW and SW;



**POLITECNICO  
DI TORINO**

- Future participation in grid balancing/ancillary markets/energy communities.

The innovation plan is done once every two years to monitor changes or any other variables. The main four future trends are:

### **SMART CHARGING**

- Dynamic smart charging systems (V1G and V2G) for ancillary markets participation;
- Vehicle 2 Grid for corporate fleets;
- «Domestic» Vehicle 2 Grid in an integrated offer for smart homes (PV, storages...);
- Grid impacts evaluations with a full deployment of e-mobility (grid asset management systems, investments planning...).

### **AUTONOMOUS DRIVING**

- Distributed infrastructures supporting autonomous driving development (sensors, internet connections...);
- 5G network as strategic infrastructure for autonomous driving full deployment.

### **INNOVATIVE BUSINESS MODELS**

- ADAS development and other driving support systems;
- Light sharing mobility services;
- Battery swapping as frequently as possible in support to corporate fleets/private use;
- Second life batteries for grid support or private offers.

### **NEW GENERATION FUELS**

- LNG for corporate fleets;
- Regulatory/economic incentives for biofuels development (especially for traction system);
- Hydrogen in the transport sectors.



**POLITECNICO  
DI TORINO**

## Local perspective on future mobility vision



**Mr Giuseppe ESTIVO**

*Mobility Division, Turin Municipality*

For the City of Torino but also for other European countries pollution is one of the main issues now-a-days. So, the common European goal:

*«By 2030 to halve in urban transport the use of automobile «fuelled by traditional fuels» and eliminate it completely by 2050; achieve a CO2-free urban logistics system in major cities by 2030»*

Transport White Paper

This goal can be achieved working on three main pillars:

- Public transport.
- Sharing Mobility
- Charger infrastructure

In the Public transport sector the City of Torino implemented eight tram lines, one metro line and four electric bus lines (from 2018)

New Policy recommendations for this sector:

- Next bus purchase calls will only provide for the purchase of electric buses
- They will invest in the tramway network to create a new line

In the Sharing Mobility sector the electric car sharing BLUETORINO operates in Turin since 2017 with 325 cars and 460 charging stations. Moreover, in 2019 the City of Torino launched the tender for micro-mobility e-bike sharing, electric motor scooter sharing and e-scooter sharing (Since January in the City there are available: 4000 e-scooters, 200 electric motor scooters and 500 pedal-assisted bicycles).

New Policy recommendations in this sector:

- Infrastructure costs were covered by the investors to whom in return the City gave free use of public land (not taxed);
- Free entrance in the LTZ and free parking in paid areas;
- The charging stations are open to the public and thus the private individual can recharge his/her car;
- Regarding micro-mobility, operators have accepted as a clause to provide their services within the city's MaaS platform which will be operational from 2020.



**POLITECNICO  
DI TORINO**



As far as concerns charging Infrastructure, in 2018 the City of Torino launched the public call for the construction of a network of charging infrastructures: 4 operators participated (Enel, Duferco, Becharge, Iren). They presented projects for the construction of 400 charging stations. Of these, 10% will be fast charge columns.

New Policy recommendations in this sector:

- Operators will have a large discount on taxes for the use of public land
- To avoid crowding in a single area, we have placed a minimum distance limit of 250 meters.

Adding as a last point Freight logistics, the City has an experimental project on zero emission logistics and a special permit has been introduced for electric vehicles that have unlimited access to the LTZ and can use the preferential lanes.

New Policy recommendations:

- Pull measures support operators to invest in the purchase of zero-emission vehicles



**POLITECNICO  
DI TORINO**

## CONCLUDING REMARKS

The webinar has accounted a wide set of ongoing solutions related to sustainable e-mobility. The solutions span from concerns at the planning scale and sustainable infrastructure, to the design of components/equipments/OEM for the new LEVs introduction. The different IA funded projects invited to discussed in this webinar has proposed alternative speculative approach to the same e-mobility goal. Despite the ultimate target is the same, each of the exposed approaches have either a technically led focus or a energy efficient one. From the perspective of STEVE project, the human centric approach relay on different data analysis, forum, interview, surveys, data monitoring, simulation and benchmark of existing reference cases. This user centric analysis has provided unique knowledge (pros and cons) about the potentials and threats of introducing piloting experiences based on LEVs. The webinar has mostly highlighted the heterogeneity of contribution which must commonly work toward the exploitation of innovative e-mobility products and services. The discussion is a guiding and integrated knowledge for many different stakeholders (from car manufacturing companies to public authorities, from service providing companies to public transport companies). In this sense, the work of Steve pilots cities has critically integrated the ongoing means of transportations which were regarding co-modality, charger planning, Maas services with the planning and regulatory activities. The output will feed further focused experiments in the near future in all the pilots cities, and according to a set of most liable features for e-mobility, a specific set of priority and recommendations were selected.

Public authorities were asked to ultimate choose from 5 group of indicators:

- Overall utility of STEVE ELVs
- Willingness to use/pay
- On board systems
- Performance, safety and comfort
- Charge, park, drop, access and booking
- 

By weighting the ultimate choices of public authorities involved in the demonstration sites of Steve, it is possible to have a fair pictures of their main recommendations and future mobility policy (see Graph 1).

In general, it is possible to see that context matters but the overall strategies are alike. In bigger context (Italy), the main priority for e-mobility are narrowed while in the other experimental site there is a propensity to widen up the possibility to implement different mobility recommendations. All the different size of Steve context are aligned in choosing as main recommendations the guiding features on the design infrastructures regarding the Charging/parking , accessibility and booking systems.



POLITECNICO  
DI TORINO

If we observe the second priority of guiding features (see Graph 2), it is possible to say that the policies vary in accordance to the envisioned future and the present condition of each country. In this "deciding dimension", Austria shows clearly in the spider gram their different and mature political vision, while Italy and Spain are implementing a variety of parallel sustainable initiatives, giving almost equal importance to all the five groups of indicators.

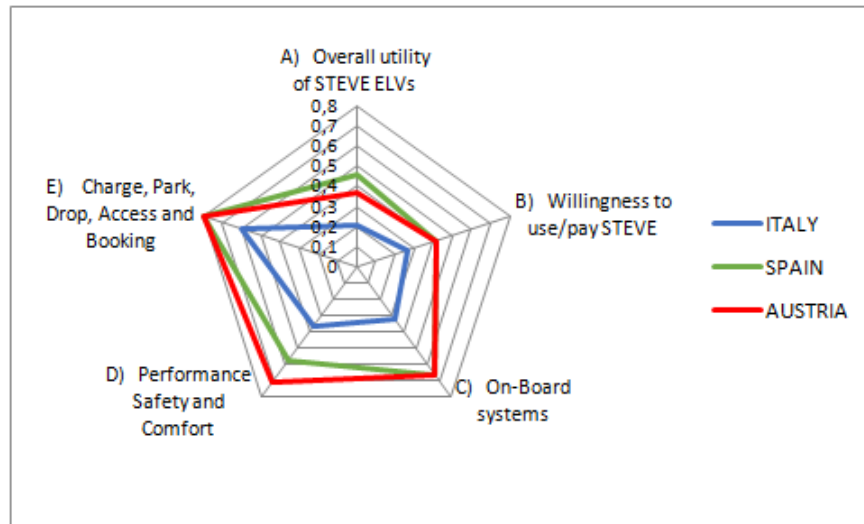

Graph 1 Weighted 1st priorities of Italian, Spanish and Austrian public partners

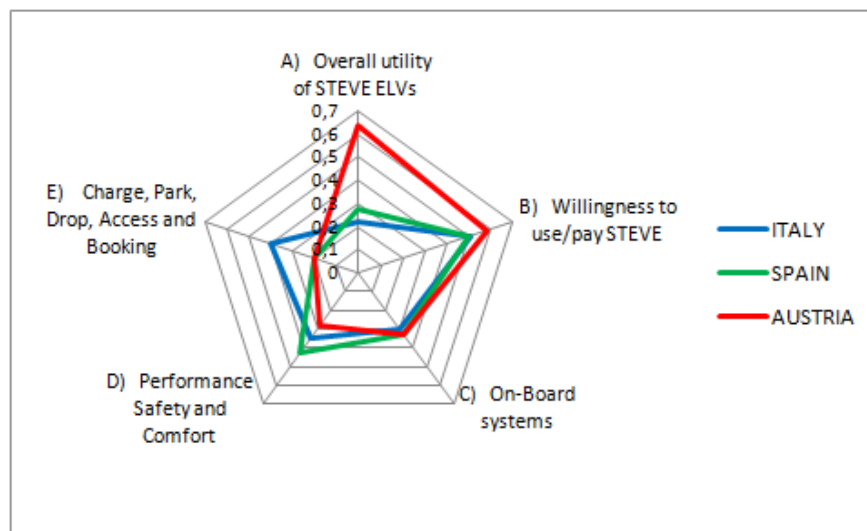

Graph 2 Weighted 2nd priorities of Italian, Spanish and Austrian public partners

# Annex 1 - WEBINAR AGENDA

*Scenarios of electro-mobility: cross-fertilization and dissemination of best practices and researches within EU policies*

## WEBINAR AGENDA

Thursday the 28<sup>th</sup> of May 2020

Start	Topic	Speakers
09:30	Welcome and introduction	<ul style="list-style-type: none"> <li>• Massimo VIOLANTE, STEVE project coordinator for the Polytechnic of Torino</li> <li>• Maria LAPIETRA, Mobility Councillor, Torino Municipality</li> <li>• Laura FERRARIS, Prefect Commissioner, Venaria Municipality</li> </ul>
10:00	First session <i>STEVE project and its main results</i>	<ul style="list-style-type: none"> <li>• Johan MASSONER, STEVE Lead Partner, Infineon</li> <li>• Matthias FELSBERGER, STEVE Partner, Infineon/Villach Municipality</li> <li>• Dolores ORDÓÑEZ, STEVE Partner, AnySolution S.L.</li> <li>• Maurizio VERONESE, 5T, City of Torino in house company</li> <li>• Diego CIPOLLINA, STEVE Partner, Venaria Municipality</li> </ul>
11:00	Second session <i>Users centric e-design for innovative technologies and services</i>	<ul style="list-style-type: none"> <li>• Daniele BARANZINI, STEVE Partner, Ospedale San Raffaele</li> <li>• Aldo SORNIOTTI, STEVE Partner, University of Surrey</li> <li>• Xu Mei Hua, STEVE Partner, JAC – Italy Design Center s.r.l.</li> <li>• Markus PISTAUER, STEVE Partner, CISC Semiconductor GmbH</li> <li>• Marco ANNONI, STEVE Partner, VEM Solution S.p.A./Viasat Group S.p.A.</li> <li>• Massimo VIOLANTE, STEVE Partner, Department of Automation and Computer Science, Polytechnic of Torino</li> <li>• Riccardo GROPPPO, STEVE Partner, Ideas &amp; Motion s.r.l.</li> </ul>
12:00	Third session <i>Policy recommendation for electro mobility</i>	<ul style="list-style-type: none"> <li>• Paolo GUGLIELMI, H2020 INVICT-EV Partner, Department of Energy, Polytechnic of Torino</li> <li>• Federico BONI CASTAGNETTI, H2020 INCIT-EV Partner, Iren S.p.A.</li> <li>• Hansjörg KAPPELLER, H2020 QUIET Partner, AIT Austrian Institute of Technology GmbH</li> <li>• Inés MUÑOZ, H2020 DOMUS Partner, Applus IDIADA</li> <li>• Christina ANAGNOSTOPOULOU, H2020 ELVITEN Partner, Institute of Communication &amp; Computer Systems</li> <li>• Giuseppe ESTIVO, Mobility Division, Municipality of Torino</li> </ul>
13.00	Round table and wrap up	
13.30	End of the webinar	

## Annex 2 - SHORT PROFILES OF THE SPEAKERS AND SCIENTIFIC COMMITTEE

### Massimo VIOLANTE



MS and PhD from Politecnico di Torino, Italy, where he is now Associate Professor, Prof. Violante's main research topics are the design and validation of embedded system for safety- and mission-critical applications, with emphasis on the use of commercial off-the-shelf components like multicore processors and field programmable gate arrays in automotive, avionic and space applications. Prof. Violante published more than 150 papers in the area of testing and designing reliable embedded systems, and he co-authored two books.

### Maria LAPIETRA

Maria Lapietra, PhD in "Automation and Transport Computerization", worked in Italy and abroad (France and Switzerland), carrying out urban redevelopment plans, impact analysis of construction sites and new industrial and commercial settlements, territorial studies and assessments on logistics projects and freight transport. She has taught courses on mobility and local public transport. In July 2016 she was appointed Councillor for Transport and Infrastructure in the Municipality of Turin by Mayor Chiara Appendino.



**POLITECNICO  
DI TORINO**

## Diego CIPOLLINA



Diego Cipollina is an architect and the main director of mobility, public works, environmental and civil protection of City of Venaria Reale. He is the manager in charge of environmental rehabilitation, energy efficiency and improvement of the safety of the municipal assets. He is in charge of managing municipal assets and maintaining, designing and building public works. He is also in charge of running local public services.

## Dolores ORDÓÑEZ

Dolores Ordoñez (female) holds a degree in Law at Deusto University, Spain and she is specialized in European Community Law and holds an Executive Master in Innovation. She has been the head of European projects in different public administrations in the Balearic Islands and in the private sector. She is vice-president of Planetic (Spanish technological platform for ICT) and vice-president of the international cluster of Tourism, TURISTEC. As technical director of AnySolution she is in charge of strategic innovative plans for public and private entities and the development of the IoT platform NADIA.



## Maurizio VERONESE



Maurizio Veronese has been dealing with digital transformation projects since the early 2000s. He has worked both in the public sector and for private companies and has been in 5T since 2015, where he worked on smart ticketing and citizen services. He is currently in charge of a business unit that deals with mobility information services and mobility as a service (MaaS).



**POLITECNICO  
DI TORINO**

## Roberta CARDACI

Roberta Cardacci has a Master Degree in real estate and urban planning. She is a leading official of the mobility sector for the city of Venaria. She manages street and public space design with the responsibility of sustainable mobility plans, infrastructure management for the municipality and every security issues. She is a licensed architect with an experience in many cooperative projects both at regional and national level, especially on the topic of sustainable mobility.



## Daniele BARANZINI



Daniele Baranzini, senior data scientist and project manager for SAFROS, PAL, STEVE and THREATS EU Funded Projects at the Ospedale San Raffaele (Italy). Head of Ergonomica. Previous Research: Agent for European Commission (11 years); +20 years' experience in Industrial/Organisational/Regulatory system for EU Research Projects (4th, 5th, 6th and 7th Framework Programmes activities). Senior Expert for the European Commission Joint Research Centre; Partner of the Major Hazard Accident Bureau, European Commission Joint Research Centre.



**POLITECNICO  
DI TORINO**

## Aldo SORNIOTTI

Aldo Sorniotti gained his M.Sc. degree in mechanical engineering and Ph.D. degree in applied mechanics from the Politecnico di Torino, Turin, Italy, in 2001 and 2005. He is a Professor in advanced vehicle engineering at the University of Surrey, Guildford, U.K., where he leads the Centre for Automotive Engineering. His research interests include vehicle dynamics control and transmission systems for electric and hybrid electric vehicles. He has authored over 100 journal and conference papers. He serves as deputy editor for the Proceedings of the Institution of Mechanical Engineers, Part C: Journal of Mechanical Engineering Science, and Associate Editor for Energies.



## Xu Mei Hua



Xu Meihua, senior project manager and general manager assistant of Jac Italy Design Centre, she's been working in the automotive field for more than 15 years overseeing the style process and external communications of the company. Being part of an OEM company which is actively focused on EV market, she took part in many EV projects and deepened her knowledge about e-mobility. In the recent years, she has been project manager for other European projects such as Autodrive, Hiperform and EVC 1000.



**POLITECNICO  
DI TORINO**



## Markus PISTAUER

Dr. Markus Pistauer is founder and CEO of CISC Semiconductor GmbH and President of CISC Semiconductor Corp. He holds a Master degree in Electrical and Electronic Engineering (1991) and a Ph.D. degree in Electronic and Control Engineering (1995), both from Graz University of Technology, Austria. Professor at the Department of Electronics at Graz University of Technology. As author and co-author of more than 70 publications in areas of computer science, soft computing, simulation, control and IC design techniques he is still also active in R&D. His technical interests cover the fields of embedded and cyber physical systems, modelling, simulation and optimization techniques.



## Marco ANNONI



Marco ANNONI is the IoT Business Unit Manager of the Viasat Group. Graduated in Electronic Engineering at the Politecnico di Torino, He achieved extensive managerial experience in the world of telecommunications. Starting in 2004, in Telecom Italia he managed the innovation and research program "ITS, Connected Vehicle and Logistics" and represented Telecom Italia in the main organizations dealing with ITS - Intelligent Transport Systems, eCall and City Logistics (e.g. ERTICO ITS Europe, TTS Italy, EeIP - European eCall Implementation Platform, GSMA Automotive SiG). He has been member of the Steering Board and Technical Committee of TSP-A, the Italian association of Telematic Service Providers and of the Managing Committee of TTS Italia, the Italian Association for ITS.



**POLITECNICO  
DI TORINO**

## Paolo GUGLIELMI

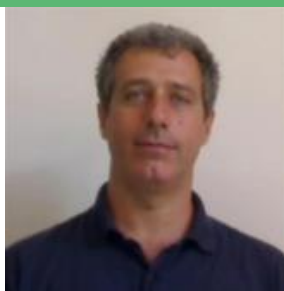

Dr. Guglielmi received his M.Sc. degree in electronic engineering and Ph.D. degree in electrical engineering from the Politecnico di Torino, Turin, Italy, in 1996 and 2001, respectively. He has authored several papers published in technical journals and conference proceedings. His fields of interest include power electronics for wireless power transfer, high-performance drives, and computer aided design of electrical machines. Dr. Guglielmi is a member of the IEEE Industry Applications Society and the IEEE Industrial Electronics Society. He has overseen several European research projects in the automotive field funded by the European Commission.

## Federico BONI CASTAGNETTI

Federico Boni Castagnetti is an environmental engineer with 4-year experience in an international Power, Oil and Gas and Infrastructure EPC Company. In 2011 he joined IREN as Technical Innovation Engineer, working in the field of power plant and district heating design and business development (feasibility studies, FEEDs, proposals definition). He is currently working in the IREN Innovation Dpt. dealing with innovation projects in several areas of IREN businesses (smart grids, e-mobility, energy and environment).



**POLITECNICO  
DI TORINO**

## Hansjörg KAPELLER



Hansjörg KAPELLER received his Dipl.-Ing. degree in electrical engineering from Vienna University of Technology, Vienna, Austria, in 2004. Since then he has been a researcher in the field of electric drives at AIT Austrian institute of Technology, Vienna. Current position / tasks: research engineer; modelling, simulation and control of electric drives; coordination of national and international research projects; managing AIT's commercial simulation libraries developed at the Competence Unit Electric Drives Technologies.

## Inés MUÑOZ

Ines studied Environmental Science and completed her Master's thesis on Environmental Science at Wageningen University in 2012. Since then, she has specialized on defining research proposals and managing projects on several fields related to climate changes, such as air quality or water management. At IDIADA, she has been managing all levels of coordination of two major H2020 projects, technical, financial and operational; building and ensuring a high level of trust communication within the project consortium.



**POLITECNICO  
DI TORINO**

## Christina ANAGNOSTOPOULOU



She received her Diploma degree from the school of Electrical & Computer engineering of the National Technical University of Athens (NTUA) in 2009, and a MSc in Environment Systems from The University of Tokyo (UTokyo) in 2013, where she continued as an international researcher in Environmental Engineering focusing on renewable energy systems and sustainability. Research interests: Electric vehicles, intelligent transport systems, energy, renewable systems, smart grid, wireless charging

## Giuseppe ESTIVO

Official of the Municipality of Torino, since 2017 he is part of the staff working for the Councillor for Mobility and Transport of the City of Torino. He is the contact person for the Infrastructure and Mobility Department for the following EU projects: NOVELOG, SOCIALCAR, SETA, IMOVE, SOLEZ, SUITS, STEVE and HARMONY . Since 2012 he is in charge of the City of Torino experimental project on the rationalization of the delivery of goods within the ZTL which the DEF (Economics and Finance Document) of the MISE (Ministry of Economic Development) mentioned in 2016 as a good practice at the national level for the policies implemented and for the stakeholder engagement model. Since 2017 he is in charge of the implementation of the first MaaS (Mobility as a Service) service in Italy to be tested on the territory of the City of Torino



**POLITECNICO  
DI TORINO**

## Giuseppe ROCCASALVA

Arch. Ph.D. and senior research fellow at Politecnico di Torino. He has international training and professional experiences in urban sustainable design and spatial planning (C.T.H and K.T.H of Sweden). He has received awards from European educational bodies and has published scientific articles on design decision support systems and scenario making processes. He is an expert in urban analyses ranging from GIS-based analyses to assessment of sustainable design ideas and plans. From 2001 he has been consultant for architectural firms, private companies and public authorities. From 2008 he has worked on sustainable environmental design and climate change processes, publishing a book title "The Future of cities and Regions" by Springer geography.



**POLITECNICO  
DI TORINO**